

4

3

2

1

NOTICE
 THIS DRAWING CONTAINS A PROPRIETARY DESIGN ASSIGNED TO SPIRA INTERNATIONAL, INC. ALL RIGHTS TO DUPLICATE, TRANSFER OR USE ARE EXPRESSLY RESERVED BY SPIRA INTERNATIONAL. THE BUYER IS LICENSED TO BUILD ONE ASSEMBLY FROM THESE PLANS.

REVISIONS				
ZONE	LTR	DESCRIPTION	DATE	APPROVED

D

D

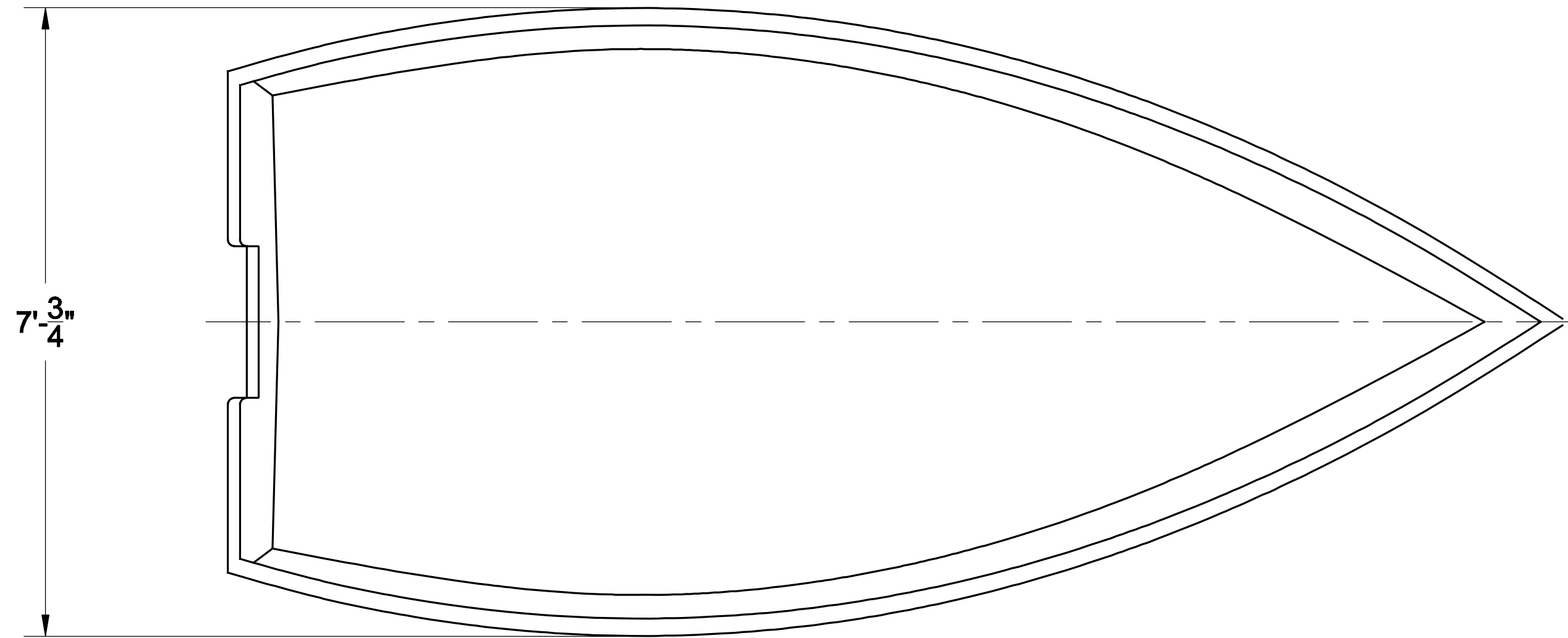

C

C

B

B

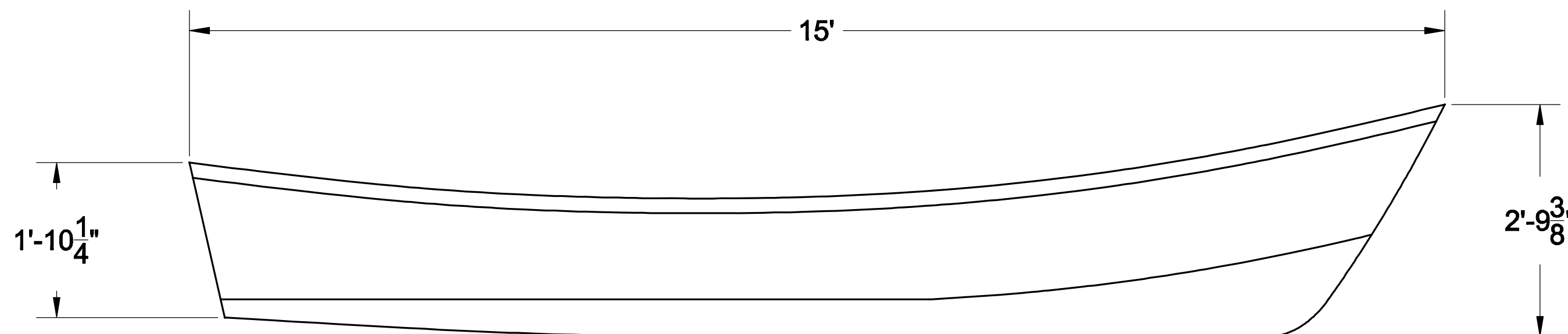

A

A

Spira International, Inc.
Huntington Beach, California

**ALAMITOS
 15' VEE BOTTOM DORY**

DRAWN BY: J. SPIRA	DATE: 10/03/08	DRAWING NO. ALAM01
SCALE 3/4" = 1'		SHEET OF

4

3

2

1

4

3

2

1

NOTICE
 THIS DRAWING CONTAINS A PROPRIETARY DESIGN ASSIGNED TO SPIRA INTERNATIONAL, INC. ALL RIGHTS TO DUPLICATE, TRANSFER OR USE ARE EXPRESSLY RESERVED BY SPIRA INTERNATIONAL. THE BUYER IS LICENSED TO BUILD ONE ASSEMBLY FROM THESE PLANS.

REVISIONS				
ZONE	LTR	DESCRIPTION	DATE	APPROVED
	A	ADDED BOM AND RENUMBERED	02/26/11	JJS

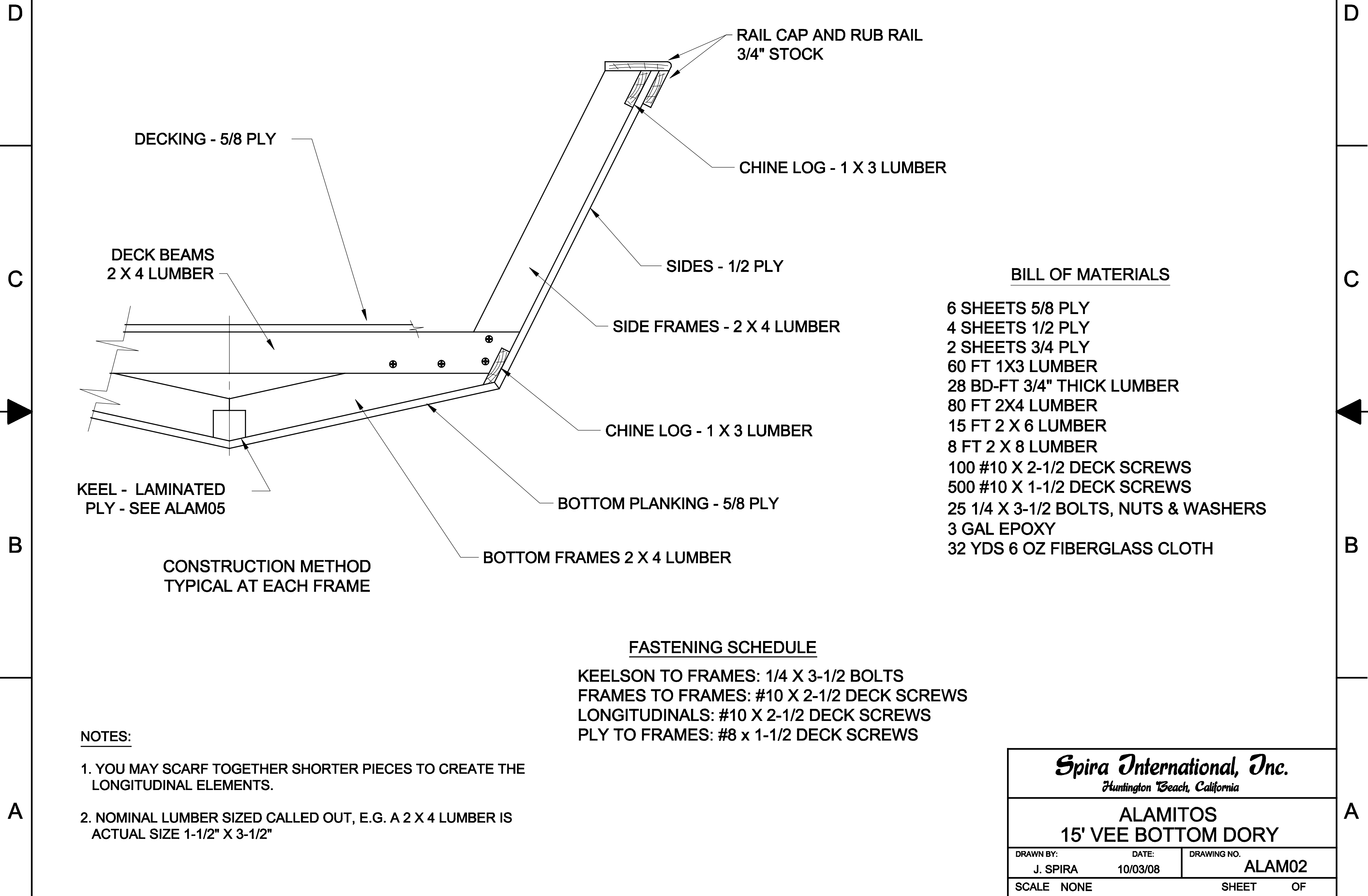

BILL OF MATERIALS

- 6 SHEETS 5/8 PLY
- 4 SHEETS 1/2 PLY
- 2 SHEETS 3/4 PLY
- 60 FT 1X3 LUMBER
- 28 BD-FT 3/4" THICK LUMBER
- 80 FT 2X4 LUMBER
- 15 FT 2 X 6 LUMBER
- 8 FT 2 X 8 LUMBER
- 100 #10 X 2-1/2 DECK SCREWS
- 500 #10 X 1-1/2 DECK SCREWS
- 25 1/4 X 3-1/2 BOLTS, NUTS & WASHERS
- 3 GAL EPOXY
- 32 YDS 6 OZ FIBERGLASS CLOTH

FASTENING SCHEDULE

- KEELSON TO FRAMES: 1/4 X 3-1/2 BOLTS
- FRAMES TO FRAMES: #10 X 2-1/2 DECK SCREWS
- LONGITUDINALS: #10 X 2-1/2 DECK SCREWS
- PLY TO FRAMES: #8 x 1-1/2 DECK SCREWS

NOTES:

1. YOU MAY SCARF TOGETHER SHORTER PIECES TO CREATE THE LONGITUDINAL ELEMENTS.
2. NOMINAL LUMBER SIZED CALLED OUT, E.G. A 2 X 4 LUMBER IS ACTUAL SIZE 1-1/2" X 3-1/2"

Spira International, Inc.
Huntington Beach, California

ALAMITOS
15' VEE BOTTOM DORY

DRAWN BY: J. SPIRA	DATE: 10/03/08	DRAWING NO. ALAM02
SCALE NONE		SHEET OF

4

3

2

1