

NOTICE
 THIS DRAWING CONTAINS A PROPRIETARY DESIGN ASSIGNED TO SPIRA INTERNATIONAL, INC. ALL RIGHTS TO DUPLICATE, TRANSFER OR SELL THIS DESIGN ARE EXPRESSLY RESERVED. THE BUYER IS LICENSED TO BUILD ONE ASSEMBLY FROM THESE PLANS.

REVISIONS				
ZONE	LTR	DESCRIPTION	DATE	APPROVED
	A	UPDATED TO NEW FORMAT	09/14/08	JJS

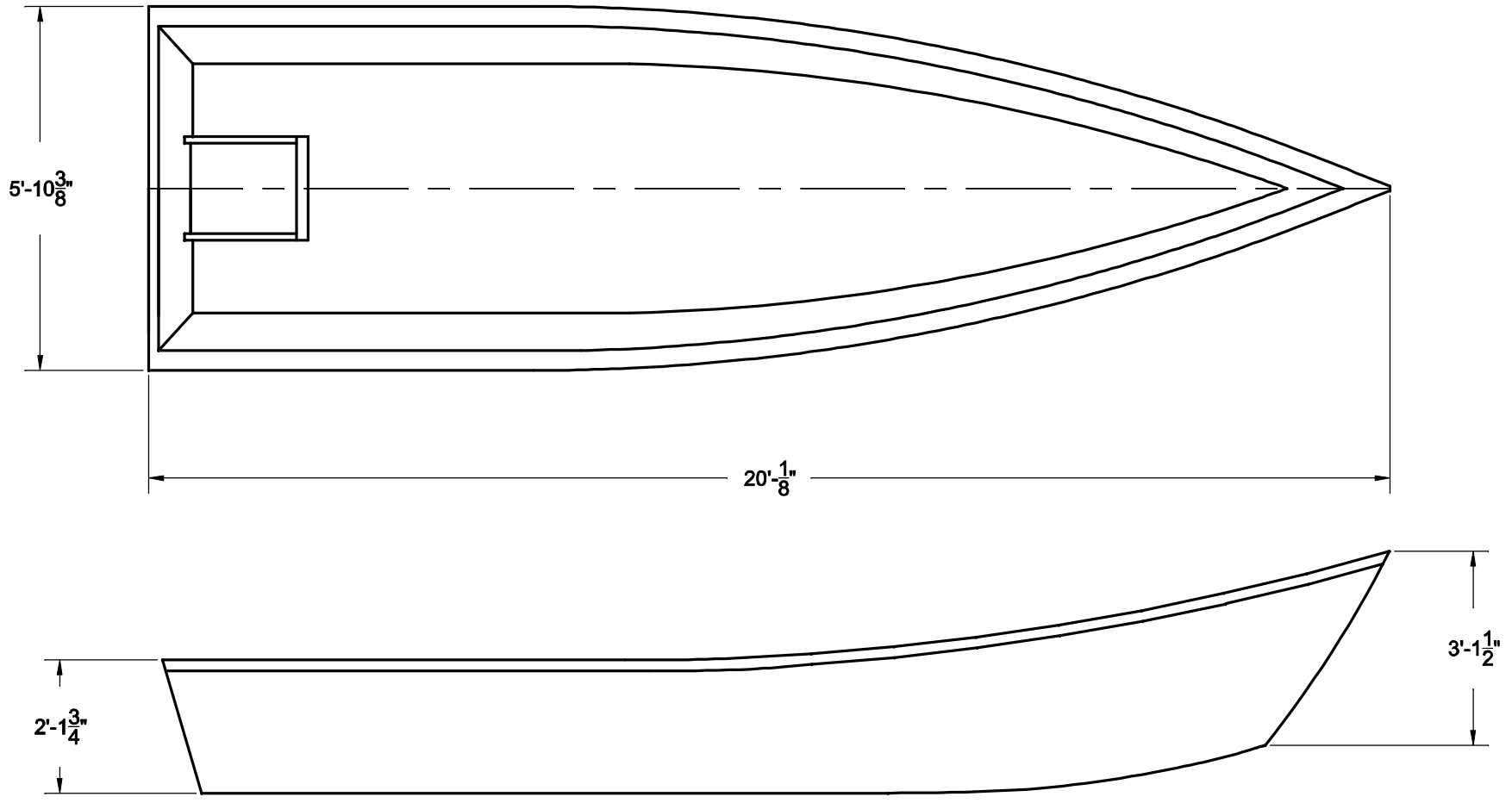

Spira International, Inc.
 Huntington Beach, California

EUREKA
 20' PACIFIC POWER DORY

DRAWN BY: J. SPIRA	DATE: 02/16/04	DRAWING NO. EURE01
SCALE 3/4" = 1'		SHEET OF

NOTICE

THIS DRAWING CONTAINS A PROPRIETARY DESIGN ASSIGNED TO SPIRA INTERNATIONAL, INC. ALL RIGHTS TO DUPLICATE, TRANSFER OR SELL THIS DESIGN ARE EXPRESSLY RESERVED. THE BUYER IS LICENSED TO BUILD ONE ASSEMBLY FROM THESE PLANS.

REVISIONS				
ZONE	LTR	DESCRIPTION	DATE	APPROVED
	A	UPDATED TO NEW FORMAT	09/14/08	JJS

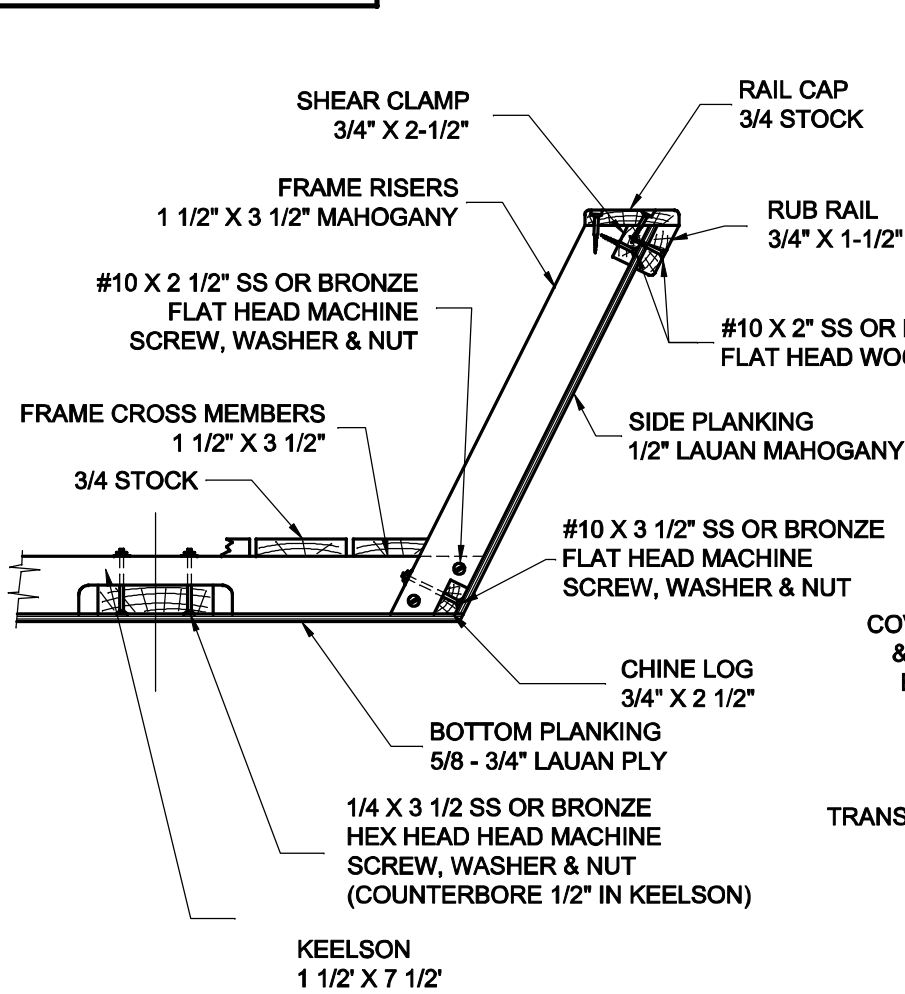

PLY BUTT BLOCK SAME THICKNESS AS PLANKING

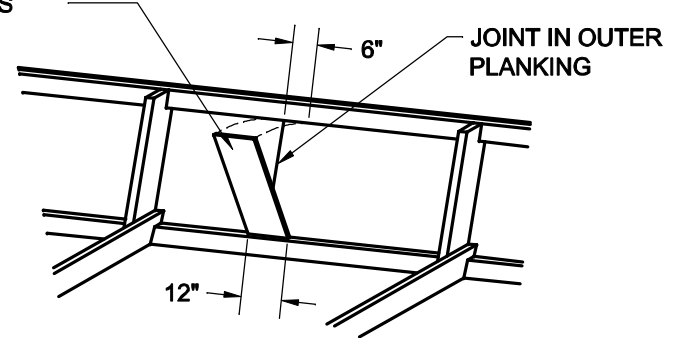

BUTT BLOCK DETAIL

USE WHEREVER PLY JOINTS OCCUR
EPOXY IN PLACE AND SCREW THROUGH OUTER PLANKING

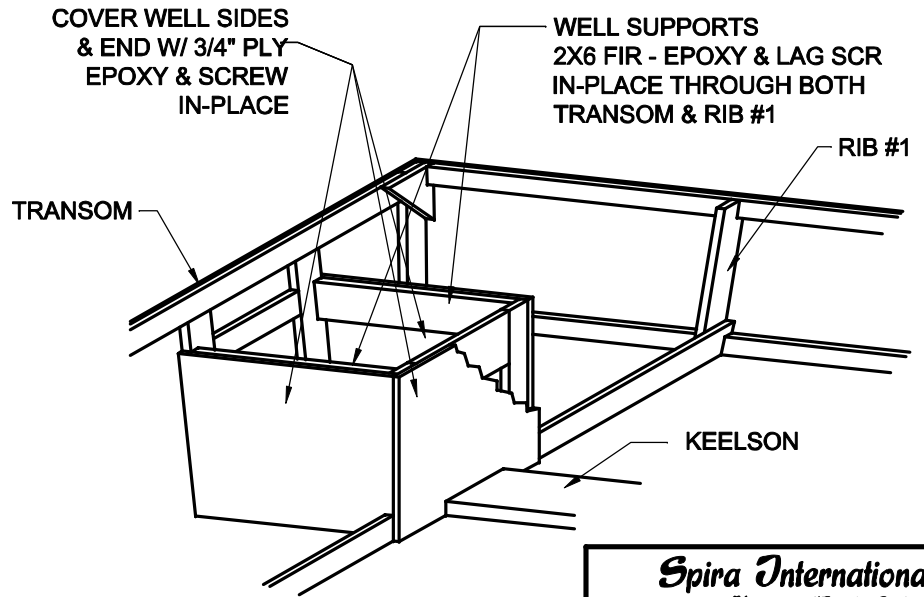

MOTOR WELL DETAILS

CONSTRUCTION DETAIL

NOT TO SCALE
TYPICAL AT EVERY FRAME

Spira International, Inc.
Huntington Beach, California

EUREKA
20' PACIFIC POWER DORY

DRAWN BY: J. SPIRA	DATE: 02/16/04	DRAWING NO. EURE04
-----------------------	-------------------	-----------------------

SCALE 3/4" = 1' & NOTED SHEET OF