

NOTICE
 THIS DRAWING CONTAINS A PROPRIETARY DESIGN ASSIGNED TO SPIRA INTERNATIONAL, INC. ALL RIGHTS TO DUPLICATE, TRANSFER OR SELL THIS DESIGN ARE EXPRESSLY RESERVED. THE BUYER IS LICENSED TO BUILD ONE ASSEMBLY FROM THESE PLANS.

REVISIONS				
ZONE	LTR	DESCRIPTION	DATE	APPROVED

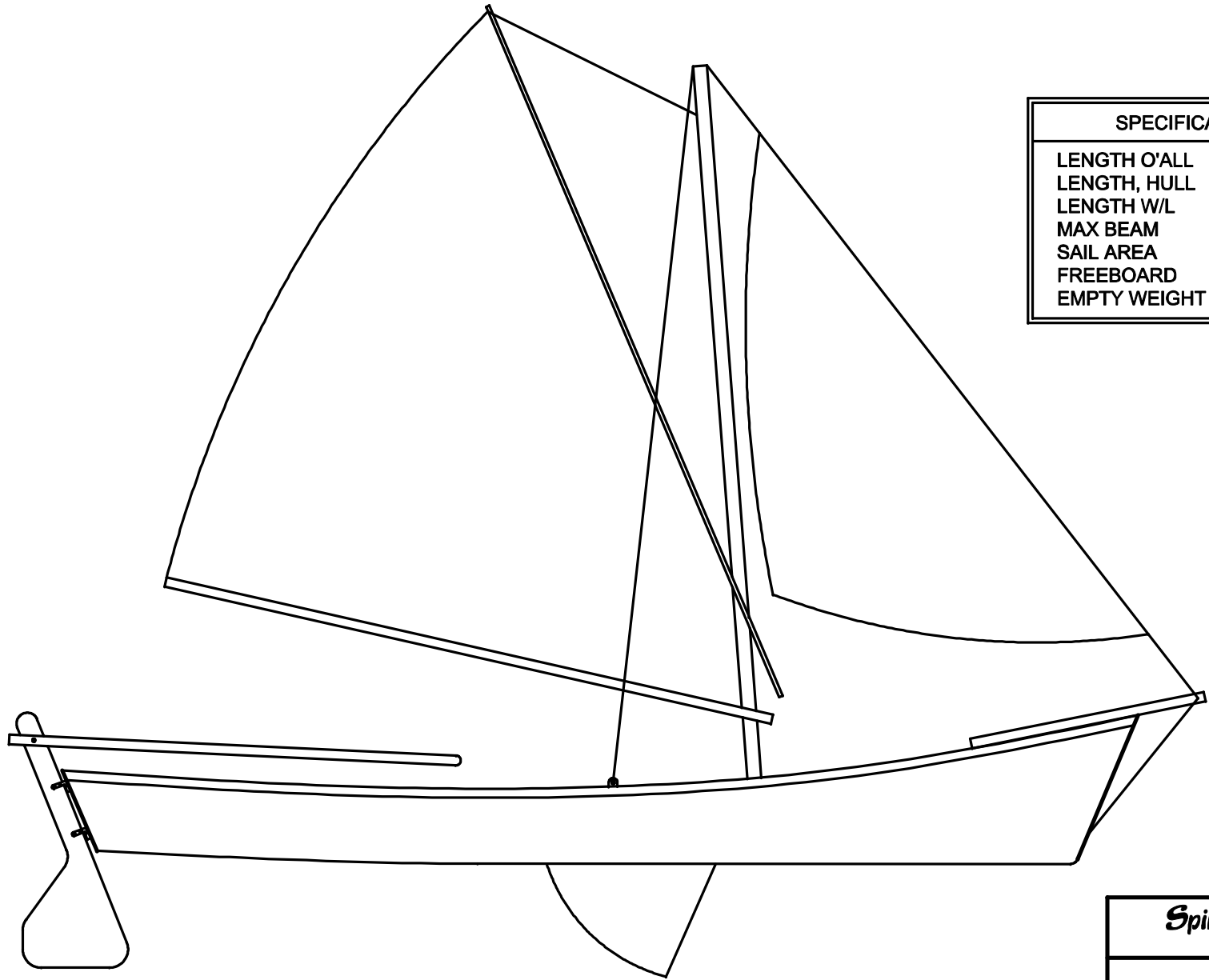

SPECIFICATIONS	
LENGTH O'ALL	15' 7"
LENGTH, HULL	14' 1"
LENGTH W/L	12' 9"
MAX BEAM	5' 8"
SAIL AREA	60.5 SQ. FT
FREEBOARD	1' 0"
EMPTY WEIGHT	450 LBS

<i>Spira International, Inc.</i> <i>Huntington Beach, California</i>		
INAGUA 14' SAILING SHARPIE		
<small>DRAWN BY:</small> J. SPIRA	<small>DATE:</small> 10/05/08	<small>DRAWING NO.</small> INAG01
<small>SCALE 1" = 1'</small>		<small>SHEET OF</small>

NOTICE

THIS DRAWING CONTAINS A PROPRIETARY DESIGN ASSIGNED TO SPIRA INTERNATIONAL, INC. ALL RIGHTS TO DUPLICATE, TRANSFER OR SELL THIS DESIGN ARE EXPRESSLY RESERVED. THE BUYER IS LICENSED TO BUILD ONE ASSEMBLY FROM THESE PLANS.

REVISIONS

ZONE	LTR	DESCRIPTION	DATE	APPROVED

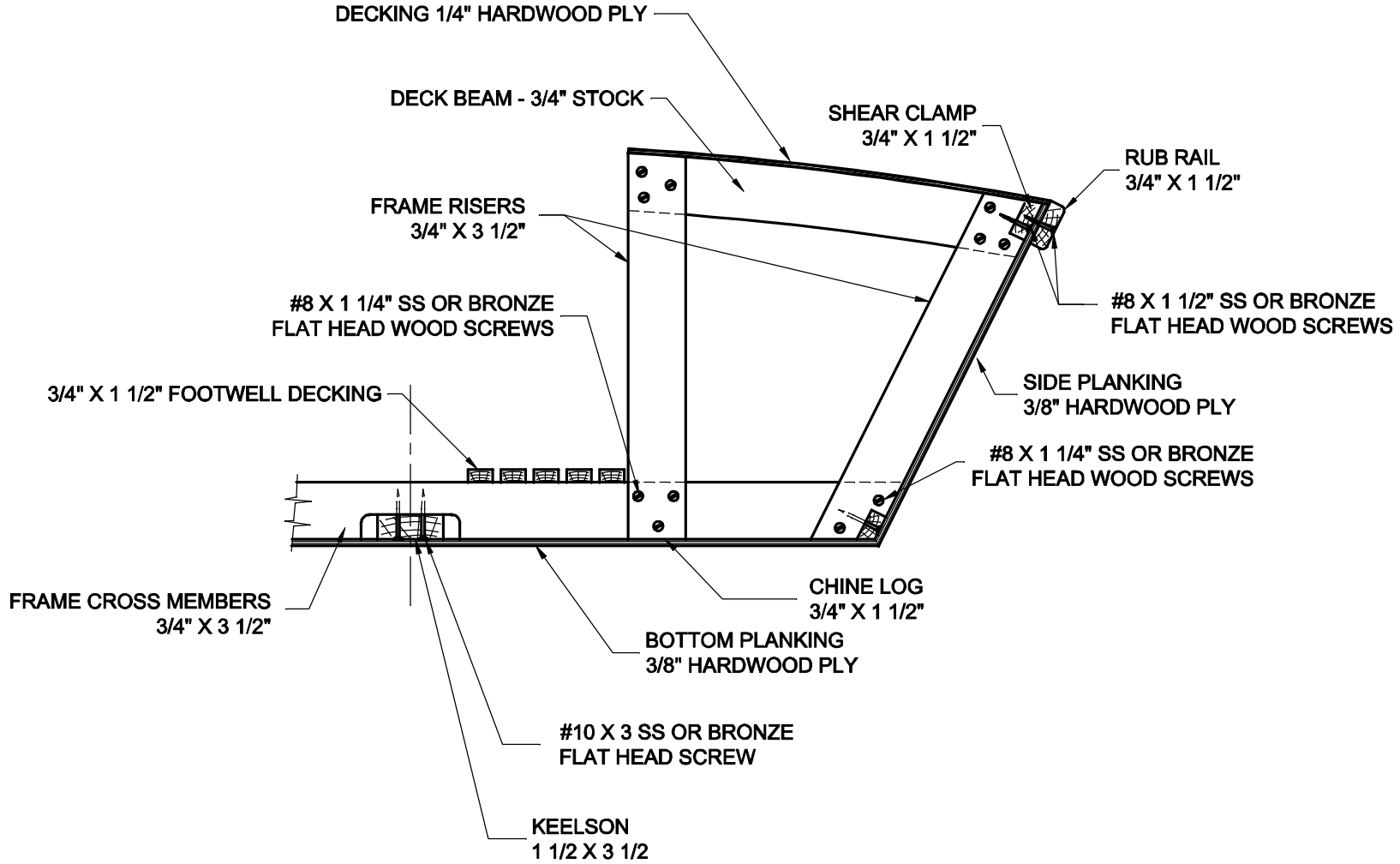

CONSTRUCTION METHOD

TYPICAL AT EACH FRAME
SCALE: 1/5

Spira International, Inc.
Huntington Beach, California

INAGUA
FRAMING DETAILS

DRAWN BY: J. SPIRA	DATE: 10/15/08	DRAWING NO. INAG02
SCALE 1' = 1' & NOTED		SHEET OF