

NOTICE
 THIS DRAWING CONTAINS A PROPRIETARY DESIGN ASSIGNED TO SPIRA INTERNATIONAL, INC. ALL RIGHTS TO DUPLICATE, TRANSFER OR SELL THIS DESIGN ARE EXPRESSLY RESERVED. THE BUYER IS LICENSED TO BUILD ONE ASSEMBLY FROM THESE PLANS.

REVISIONS				
ZONE	LTR	DESCRIPTION	DATE	APPROVED
	A	UPDATED TO NEW FORMAT	09/20/08	JJS

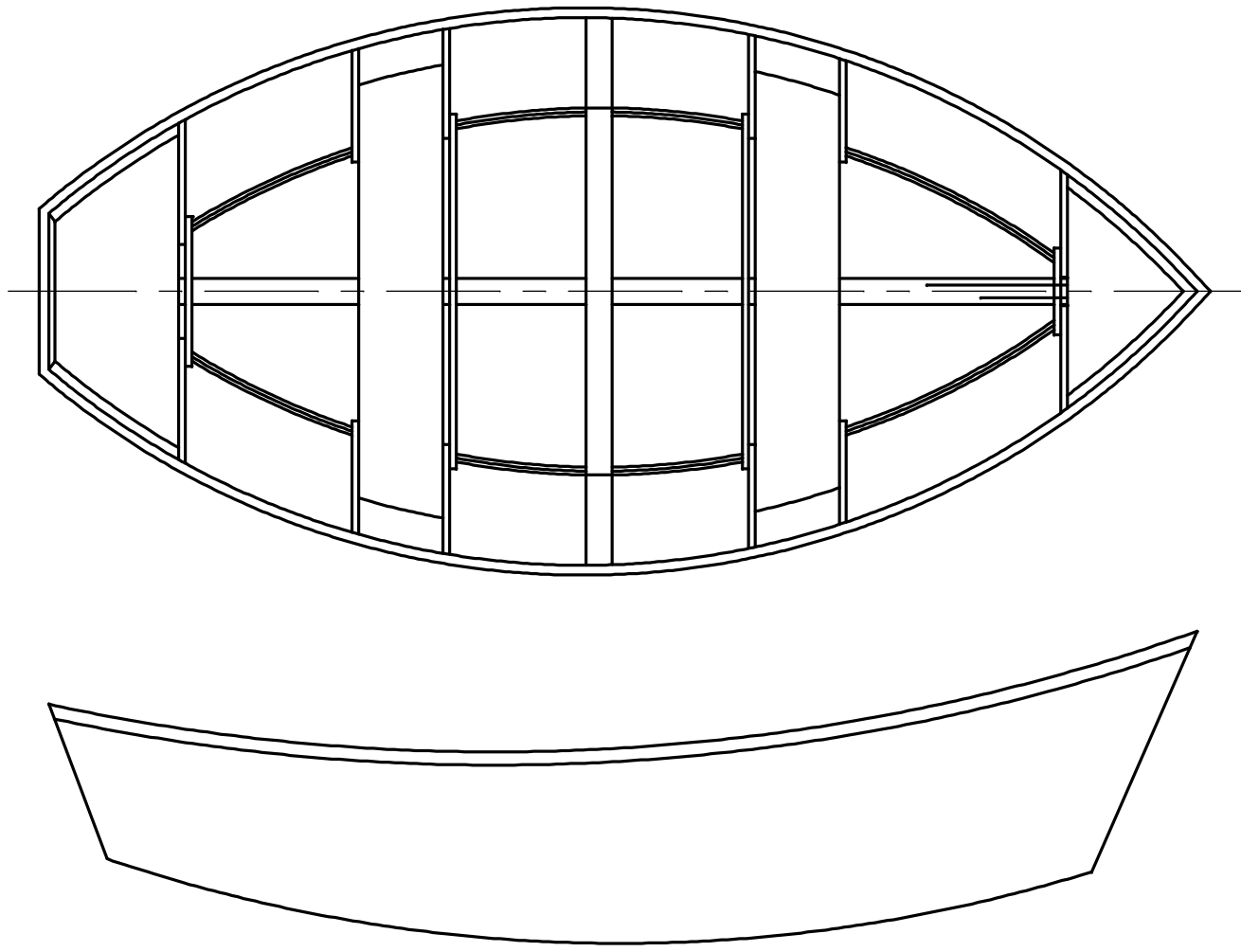

MACKINAW	
LENGTH	3.93 M
BEAM	1.90 M
FREEBOARD	0.81 M

ALL DIMENSIONS IN MILLIMETERS

Spira International, Inc.
Huntington Beach, California

MACKINAW
 MCKENZIE RIVER DRIFT BOAT

DRAWN BY: J. SPIRA	DATE: 10/18/05	DRAWING NO. MACK01M
SCALE 1" = 1'	SHEET OF	

NOTICE

THIS DRAWING CONTAINS A PROPRIETARY DESIGN ASSIGNED TO SPIRA INTERNATIONAL, INC. ALL RIGHTS TO DUPLICATE, TRANSFER OR SELL THIS DESIGN ARE EXPRESSLY RESERVED. THE BUYER IS LICENSED TO BUILD ONE ASSEMBLY FROM THESE PLANS.

REVISIONS

ZONE	LTR	DESCRIPTION	DATE	APPROVED
	A	UPDATED TO NEW FORMAT	09/20/08	JJS

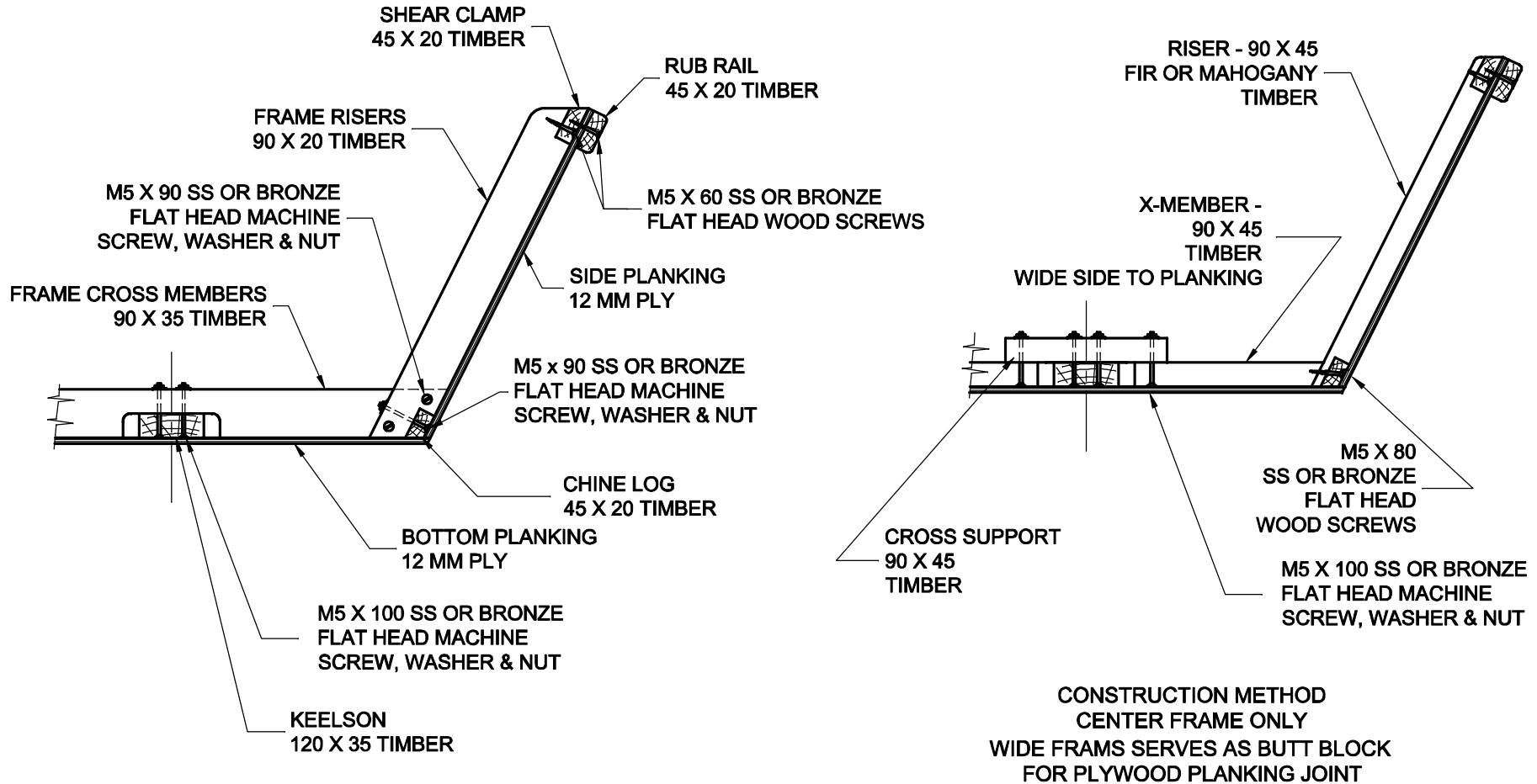

CONSTRUCTION METHOD
TYPICAL AT EACH FRAME

CONSTRUCTION METHOD
CENTER FRAME ONLY
WIDE FRAMES SERVES AS BUTT BLOCK
FOR PLYWOOD PLANKING JOINT

ALL DIMENSIONS IN MILLIMETERS

Spira International, Inc.
Huntington Beach, California

MACKINAW
CONSTRUCTION DETAILS

DRAWN BY: J. SPIRA	DATE: 10/18/05	DRAWING NO. MACK03M
SCALE 1/5 & NOTED		SHEET OF