

4

3

2

1

NOTICE
 THIS DRAWING CONTAINS A PROPRIETARY DESIGN ASSIGNED TO SPIRA INTERNATIONAL, INC. ALL RIGHTS TO DUPLICATE, TRANSFER OR SELL THIS DESIGN ARE EXPRESSLY RESERVED. THE BUYER IS LICENSED TO BUILD ONE ASSEMBLY FROM THESE PLANS.

REVISIONS				
ZONE	LTR	DESCRIPTION	DATE	APPROVED
	A	UPDATED TO NEW FORMAT	08/29/08	JJS

D

D

C

C

B

B

A

A

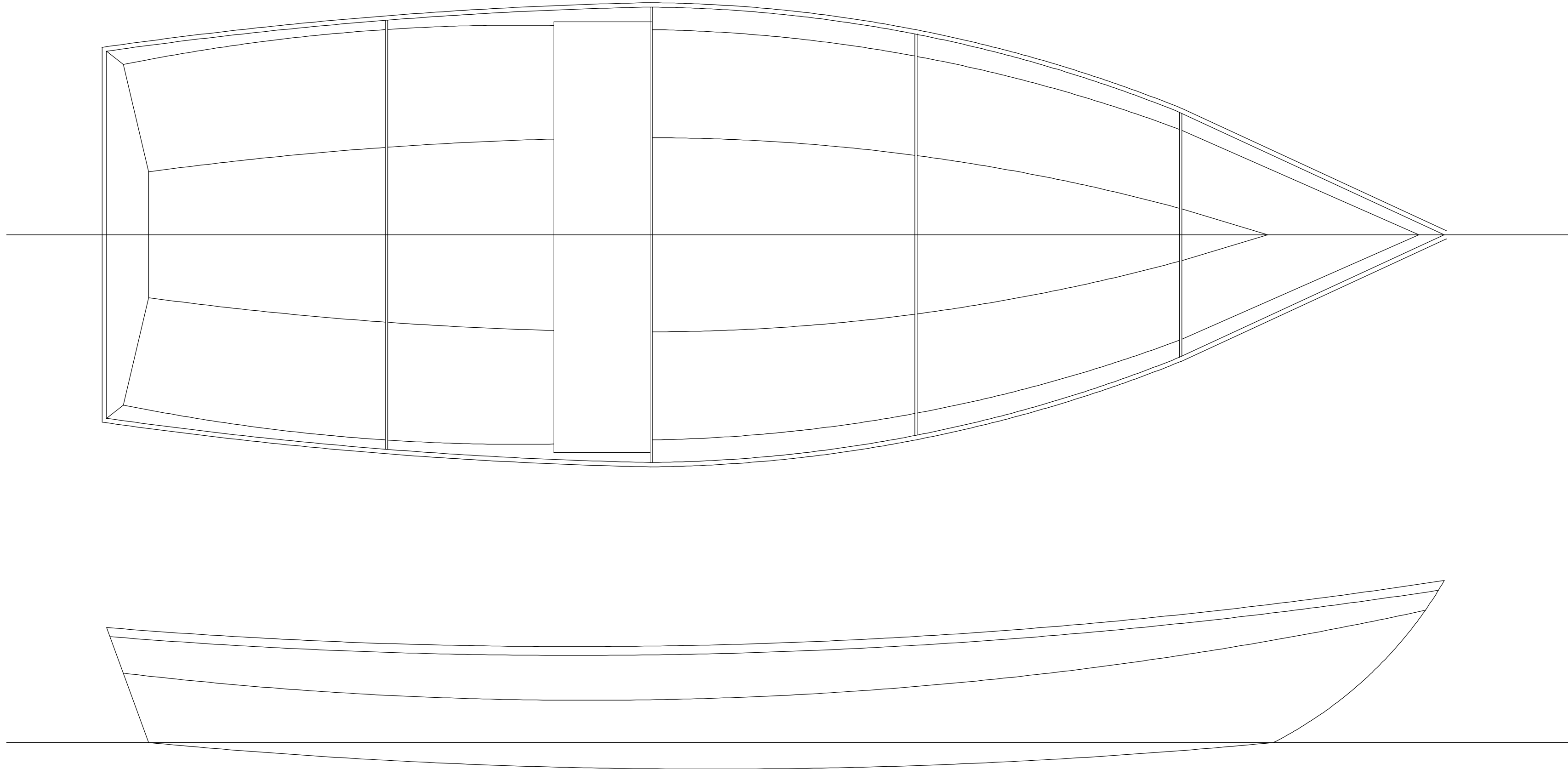

SPECIFICATIONS	
LENGTH	13' 2"
BEAM	4' 5"
HEIGHT	1' 7"
DRAFT	0' 3"
WEIGHT	56 LBS

Spira International, Inc.
Huntington Beach, California

MINUTEMAN
BATEAU 5 PLANK DORY

DRAWN BY: J. SPIRA	DATE: 7/31/97	DRAWING NO. MINU01
SCALE 1/10	SHEET OF	

4

3

2

1

NOTICE
 THIS DRAWING CONTAINS A PROPRIETARY DESIGN ASSIGNED TO SPIRA INTERNATIONAL, INC. ALL RIGHTS TO DUPLICATE, TRANSFER OR SELL THIS DESIGN ARE EXPRESSLY RESERVED. THE BUYER IS LICENSED TO BUILD ONE ASSEMBLY FROM THESE PLANS.

REVISIONS				
ZONE	LTR	DESCRIPTION	DATE	APPROVED
	A	UPDATED TO NEW FORMAT	08/29/08	JJS

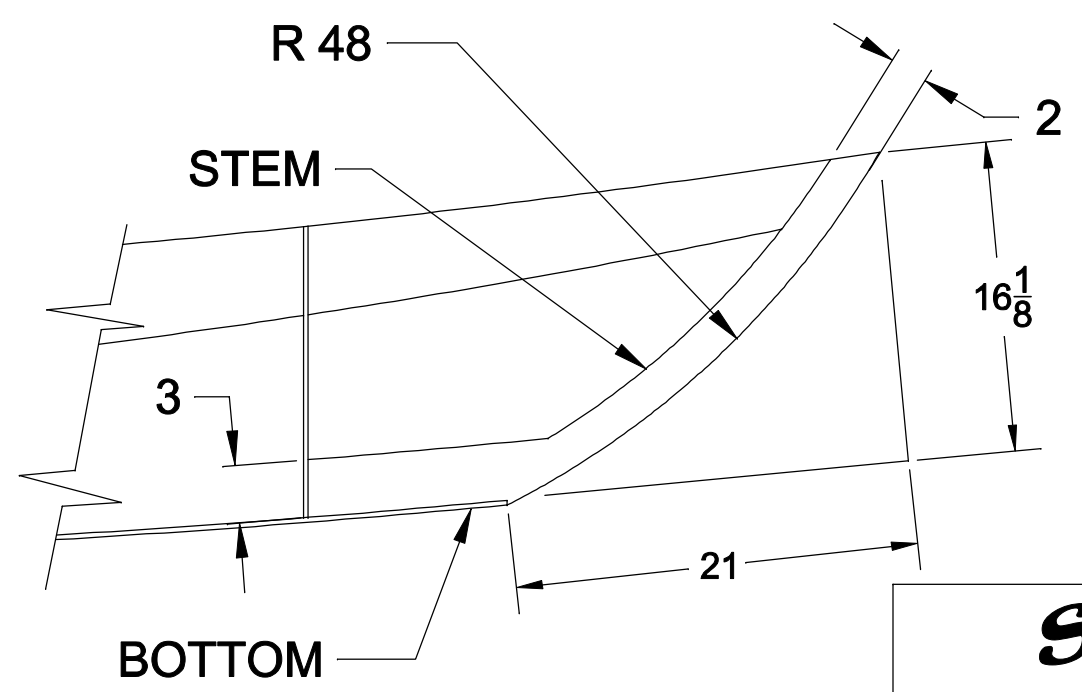
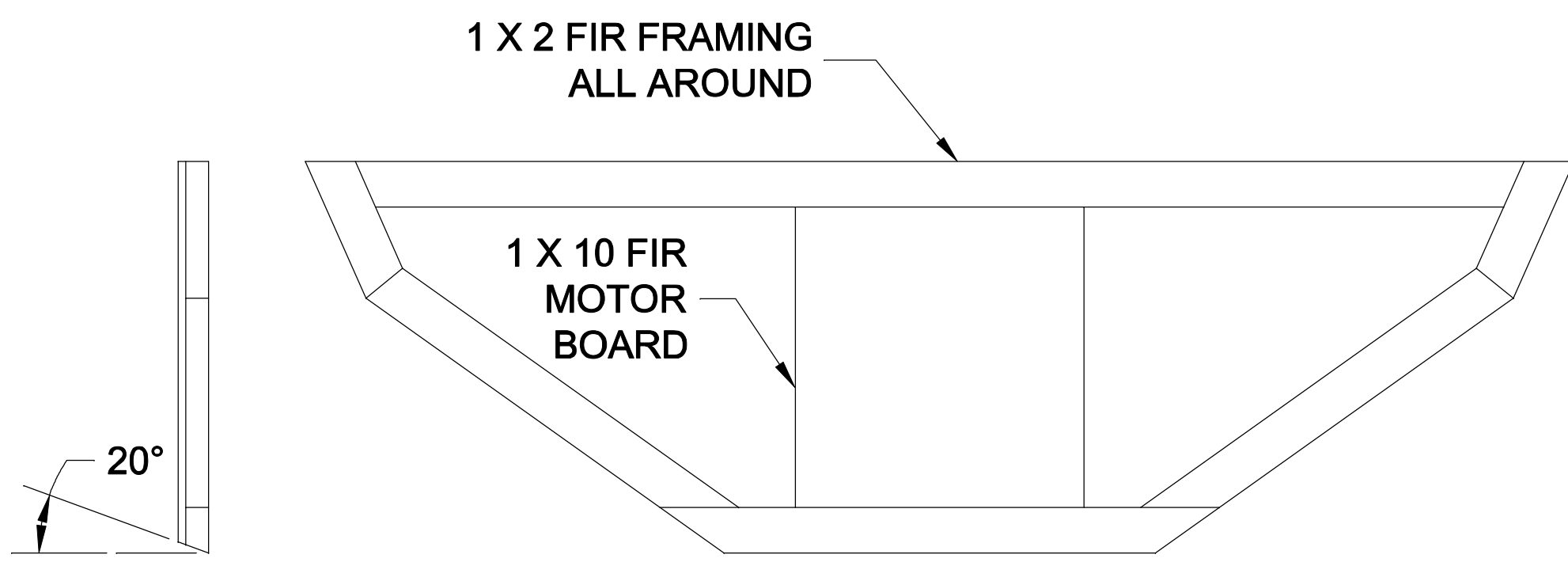
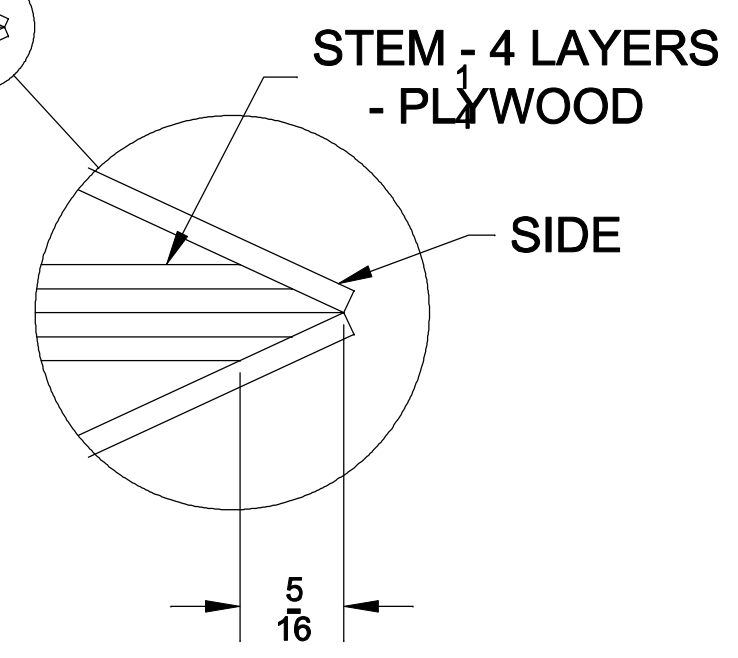
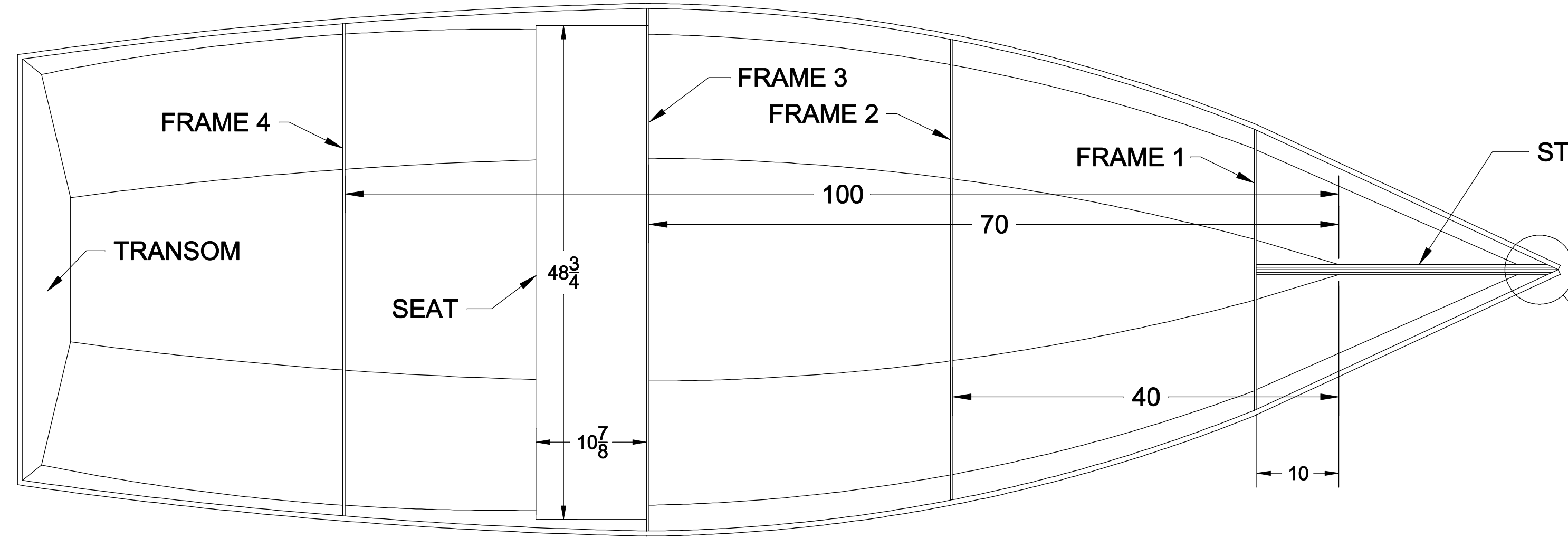
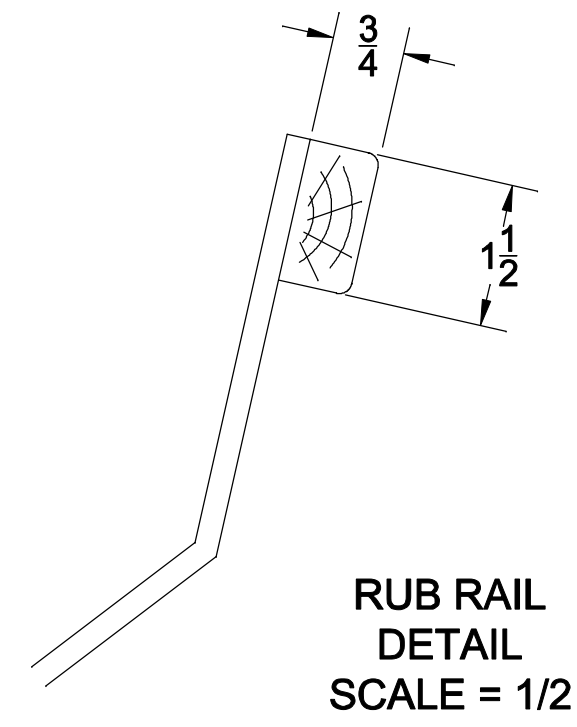
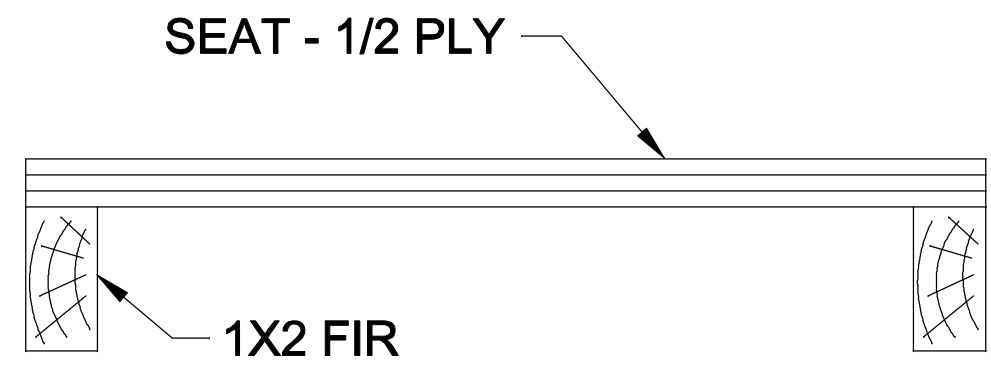

Spira International, Inc.
 Huntington Beach, California

MINUTEMAN
 BATEAU 5 PLANK DORY

DRAWN BY: J. SPIRA	DATE: 8/02/97	DRAWING NO. MINU03
SCALE 1/10	SHEET OF	

Minuteman Bill of Materials

- 4 - 4' x 8' Sheet 1/4" thick Lauan or Birch plywood
- 2 - 16' long 3/4" x 1-1/2" clear pine (or fir) molding
- 1 - 1/4 Sheet 1/2" ACX plywood (for seat)
- 2 - 8' long 1x2 clear pine or fir
- 1 - 1' long 1x10 clear pine or fir
- 1 1/2 - Gallon Epoxy
- 40 yds - 2" wide light fiberglass tape
- 1 - Doz #8 x 1" stainless steel screws
- A dozen or so inexpensive disposable paint brushes of various widths
- Rubber gloves
- Respirators (for sanding dust) & safety glasses