

4

3

2

1

NOTICE
 THIS DRAWING CONTAINS A PROPRIETARY DESIGN ASSIGNED TO SPIRA INTERNATIONAL, INC. ALL RIGHTS TO DUPLICATE, TRANSFER OR SELL THIS DESIGN ARE EXPRESSLY RESERVED. THE BUYER IS LICENSED TO BUILD ONE ASSEMBLY FROM THESE PLANS.

REVISIONS				
ZONE	LTR	DESCRIPTION	DATE YR/MO/DA	APPROVED

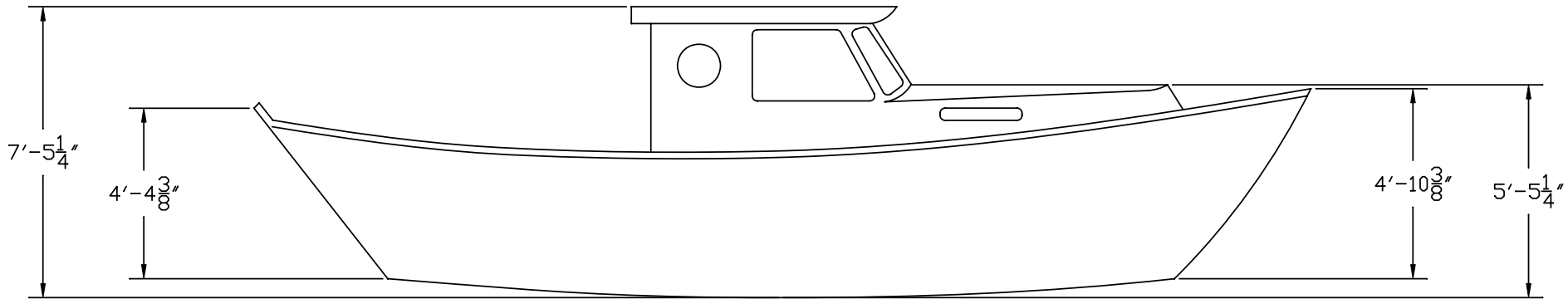
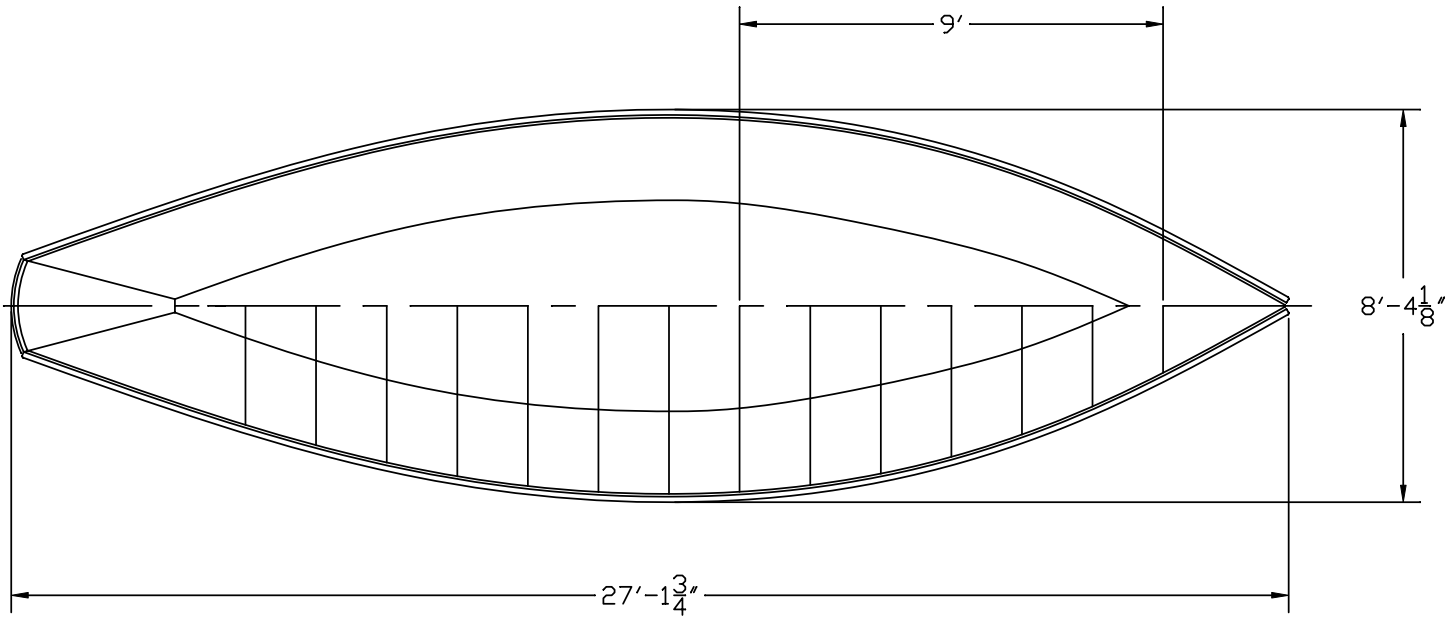

Spira International, Inc.
 Huntington Beach, California

NEWFIE
 27' GRAND BANKS DORY

DRAWN BY: J. SPIRA	DATE: 09/03/06	DRAWING NO. NEWF01
-----------------------	-------------------	-----------------------

SCALE 1/2" = 1' SHEET OF

4

3

2

1

4

3

2

1

NOTICE
 THIS DRAWING CONTAINS A PROPRIETARY DESIGN ASSIGNED TO SPIRA INTERNATIONAL, INC. ALL RIGHTS TO DUPLICATE, TRANSFER OR SELL THIS DESIGN ARE EXPRESSLY RESERVED. THE BUYER IS LICENSED TO BUILD ONE ASSEMBLY FROM THESE PLANS.

REVISIONS				
ZONE	LTR	DESCRIPTION	DATE YR/MO/DA	APPROVED

D

D

C

C

B

B

A

A

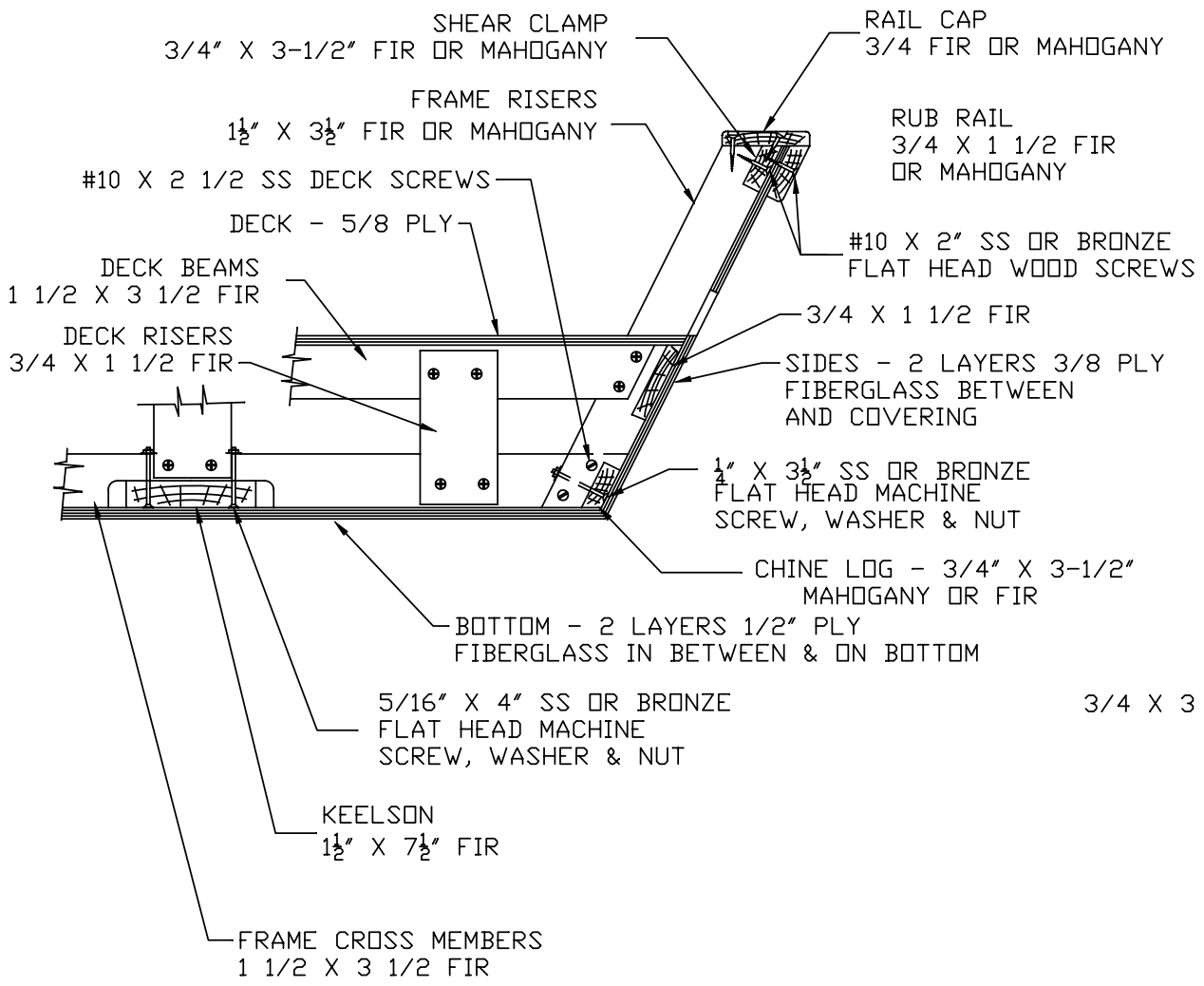

CONSTRUCTION DETAIL
 TYPICAL AT AFT SECTION
 NO SCALE

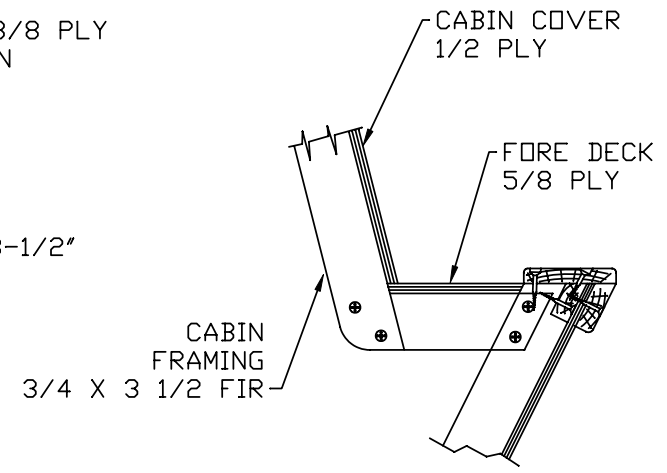

FORWARD SECTIONS
 CABIN CONSTRUCTION
 NO SCALE

Spira International, Inc.
 Huntington Beach, California

NEWFIE
 27' GRAND BANKS DORY

DRAWN BY: J. SPIRA	DATE: 01/14/08	DRAWING NO. NEWF04
-----------------------	-------------------	-----------------------

SCALE 1/2" = 1' & NOTED SHEET OF

4

3

2

1