

4

3

2

1

NOTICE
 THIS DRAWING CONTAINS A PROPRIETARY DESIGN ASSIGNED TO SPIRA INTERNATIONAL, INC. ALL RIGHTS TO DUPLICATE, TRANSFER OR SELL THIS DESIGN ARE EXPRESSLY RESERVED. THE BUYER IS LICENSED TO BUILD ONE ASSEMBLY FROM THESE PLANS.

| REVISIONS | | | | |
|-----------|-----|-------------|---------------|----------|
| ZONE | LTR | DESCRIPTION | DATE YR/MO/DA | APPROVED |
| | | | | |

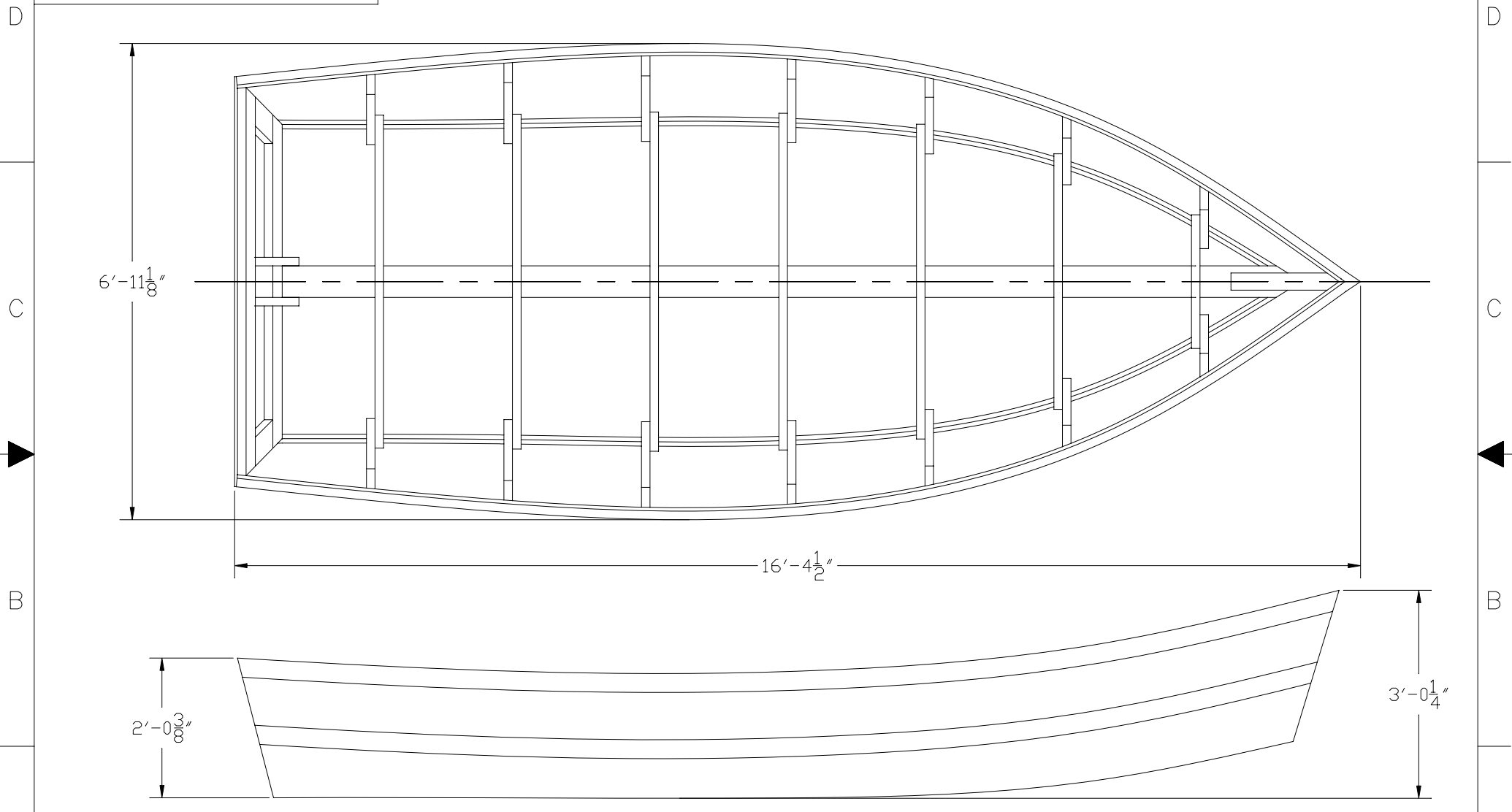

D

D

C

C

B

B

A

A

4

3

2

1

Spira International, Inc.
 Huntington Beach, California

TILLAMOOK
 16' PACIFIC POWER DORY

| | | |
|-----------------------|-------------------|-----------------------|
| DRAWN BY: J. SPIRA | DATE: 09/28/07 | DRAWING NO. TILL01 |
|-----------------------|-------------------|-----------------------|

SCALE 1" = 1' SHEET OF

4

3

2

1

NOTICE
 THIS DRAWING CONTAINS A PROPRIETARY DESIGN ASSIGNED TO SPIRA INTERNATIONAL, INC. ALL RIGHTS TO DUPLICATE, TRANSFER OR SELL THIS DESIGN ARE EXPRESSLY RESERVED. THE BUYER IS LICENSED TO BUILD ONE ASSEMBLY FROM THESE PLANS.

| REVISIONS | | | | |
|-----------|-----|-------------|---------------|----------|
| ZONE | LTR | DESCRIPTION | DATE YR/MO/DA | APPROVED |
| | | | | |

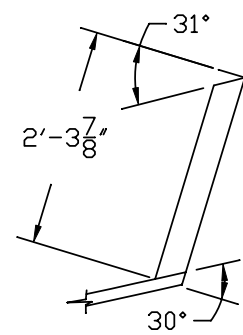
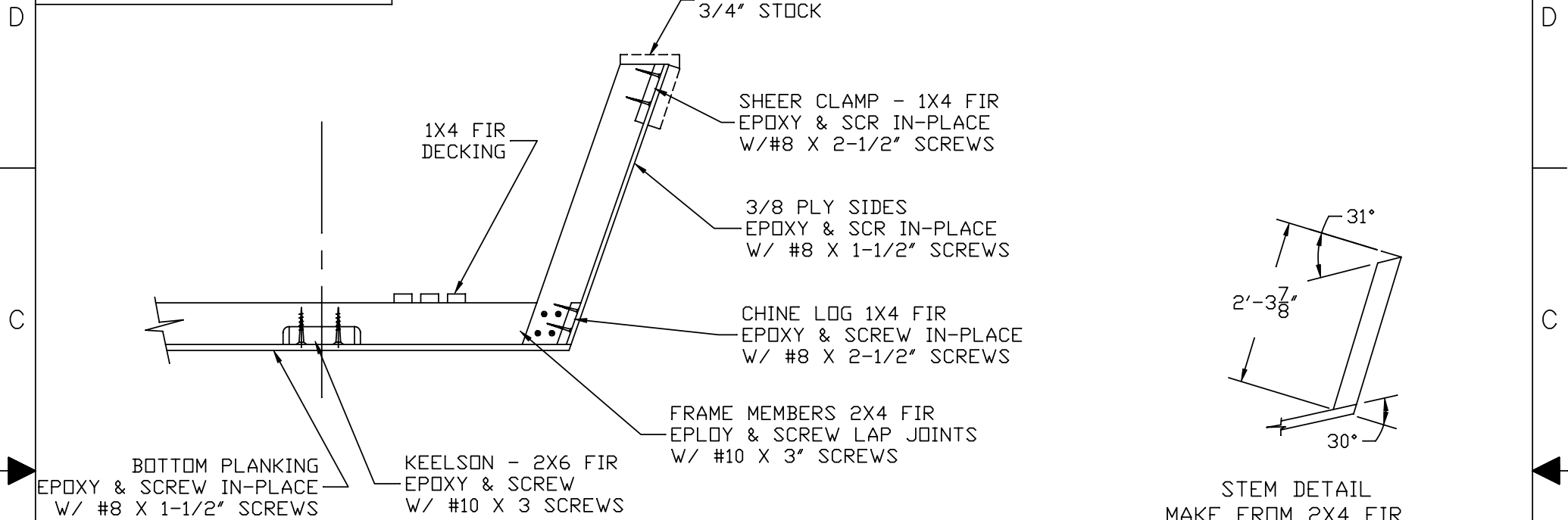

STEM DETAIL
 MAKE FROM 2X4 FIR

TYPICAL CONSTRUCTION METHOD
 ALL FRAME STATIONS
 SCALE 2" = 1'

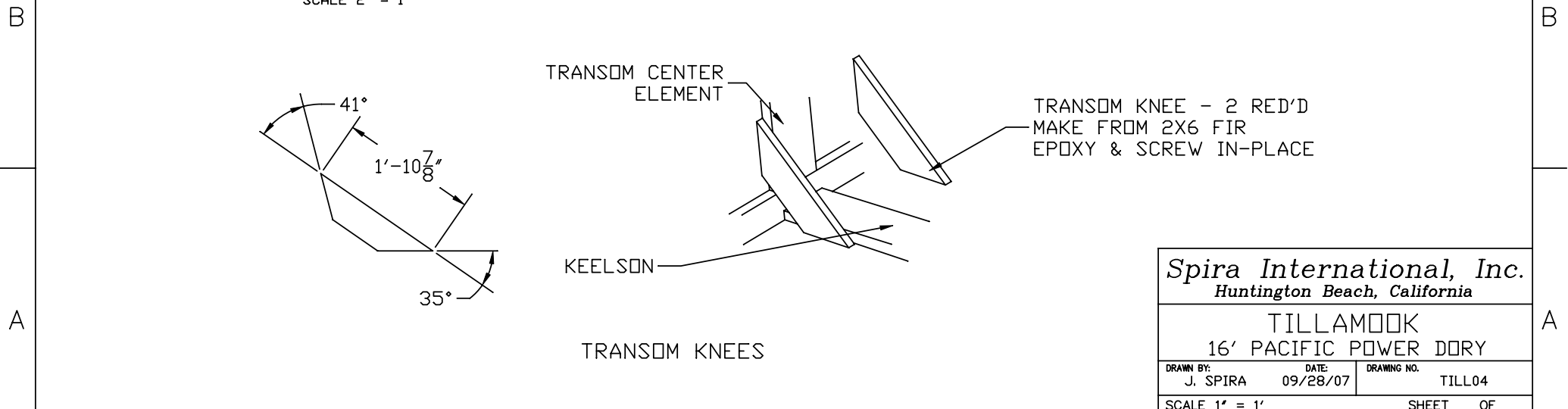

Spira International, Inc.
 Huntington Beach, California

TILLAMOOK
 16' PACIFIC POWER DORY

| | | |
|-----------------------|-------------------|-----------------------|
| DRAWN BY: J. SPIRA | DATE: 09/28/07 | DRAWING NO. TILL04 |
| SCALE 1" = 1' | | SHEET OF |

4

3

2

1