

NOTICE  
 THIS DRAWING CONTAINS A PROPRIETARY DESIGN ASSIGNED TO SPIRA INTERNATIONAL, INC. ALL RIGHTS TO DUPLICATE, TRANSFER OR SELL THIS DESIGN ARE EXPRESSLY RESERVED. THE BUYER IS LICENSED TO BUILD ONE ASSEMBLY FROM THESE PLANS.

REVISIONS				
ZONE	LTR	DESCRIPTION	DATE	APPROVED
	A	UPDATED TO NEW FORMAT	09/30/08	JJS

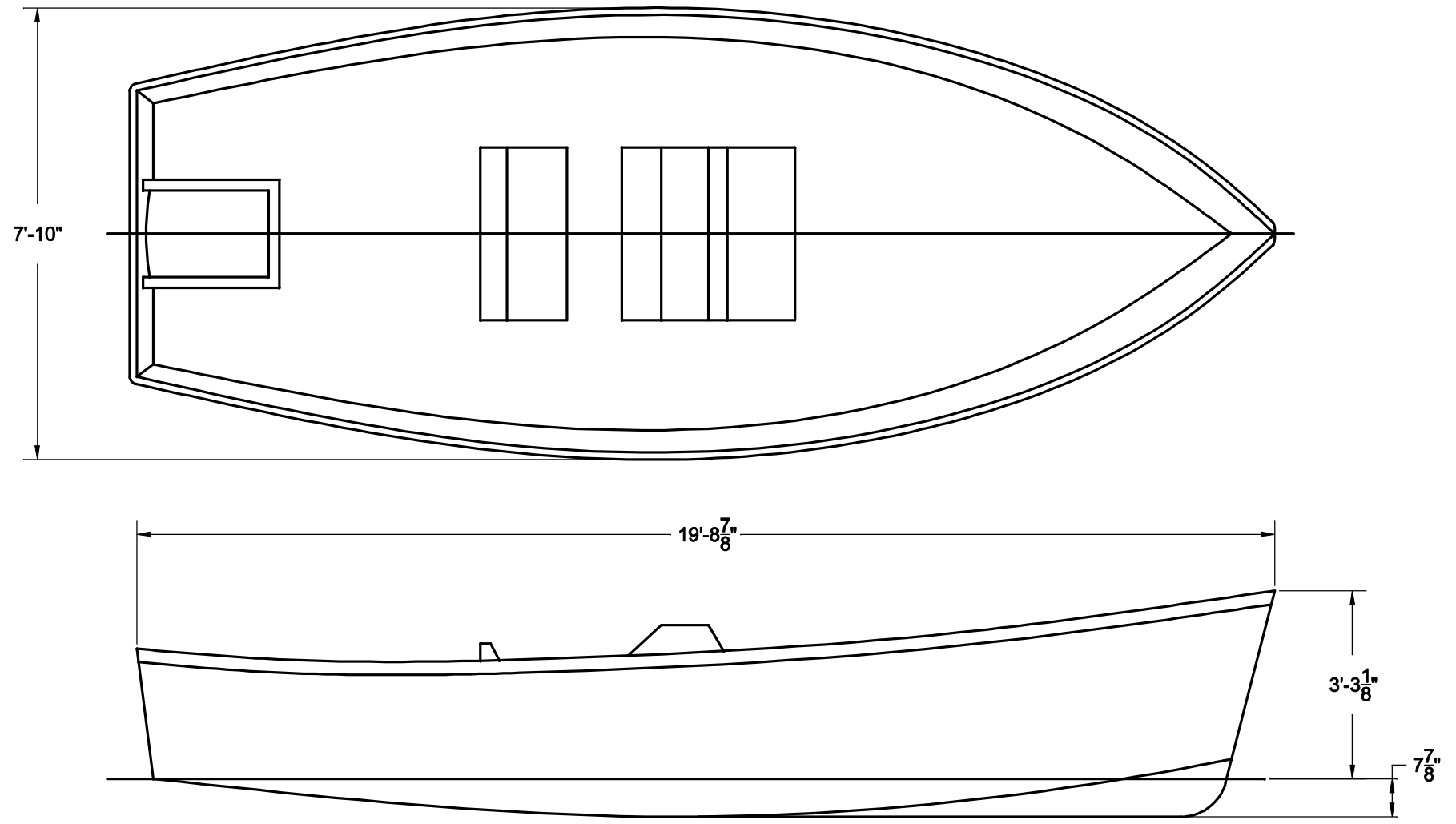

**Spira International, Inc.**  
*Huntington Beach, California*

**TORTUGA**  
**20' MULLET SKIFF**

DRAWN BY: J. SPIRA	DATE: 07/26/05	DRAWING NO. TORT01
SCALE 3/4" = 1'		SHEET OF

NOTICE

THIS DRAWING CONTAINS A PROPRIETARY DESIGN ASSIGNED TO SPIRA INTERNATIONAL, INC. ALL RIGHTS TO DUPLICATE, TRANSFER OR SELL THIS DESIGN ARE EXPRESSLY RESERVED. THE BUYER IS LICENSED TO BUILD ONE ASSEMBLY FROM THESE PLANS.

REVISIONS

ZONE	LTR	DESCRIPTION	DATE	APPROVED
	A	UPDATED TO NEW FORMAT	10/01/08	JJS

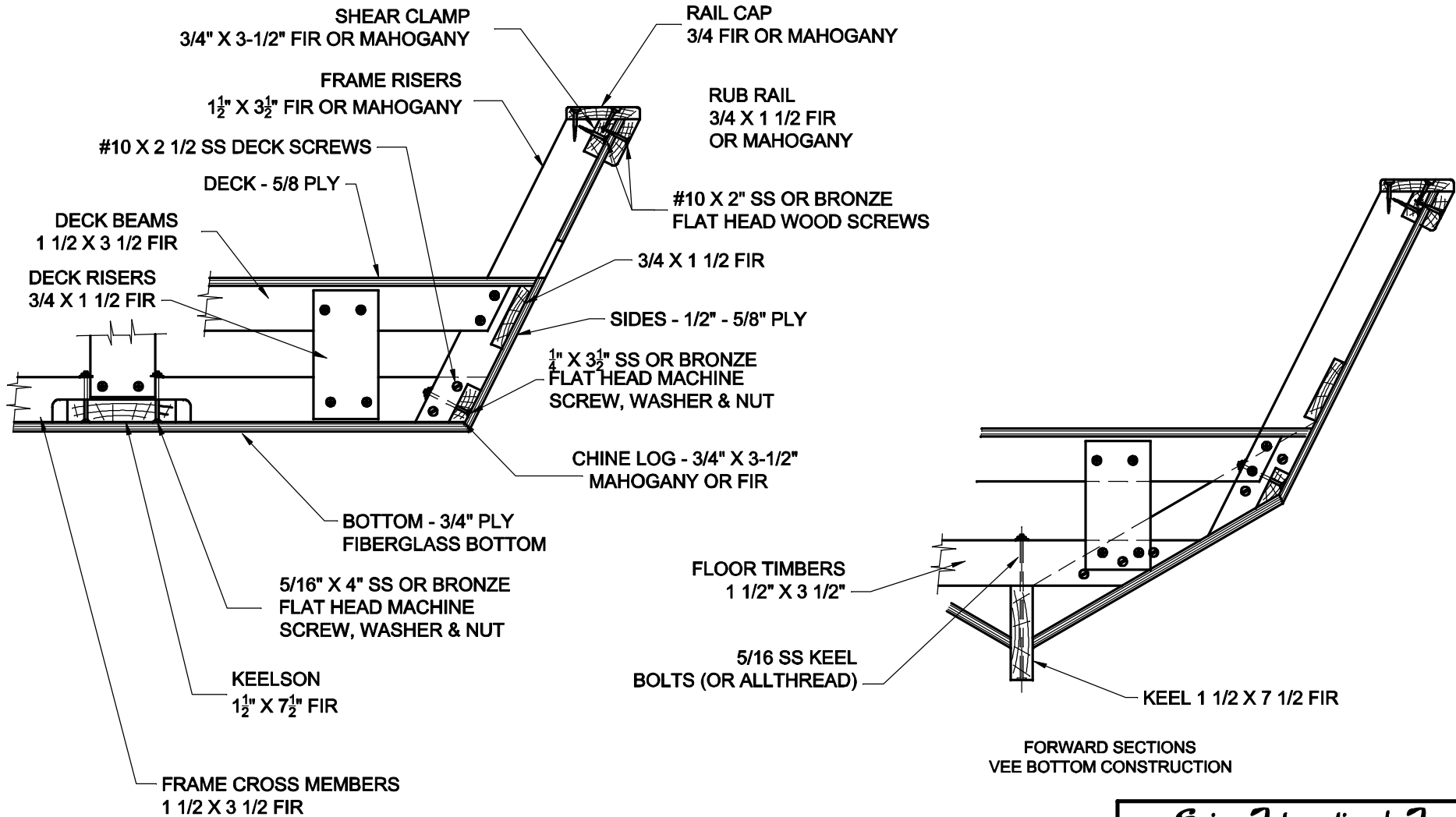

CONSTRUCTIONS DETAIL

TYPICAL AT AFT SECTION  
NOT TO SCALE

FORWARD SECTIONS  
VEE BOTTOM CONSTRUCTION

**Spira International, Inc.**  
Huntington Beach, California

**TORTUGA**  
20' MULLET SKIFF

DRAWN BY: J. SPIRA	DATE: 07/28/05	DRAWING NO. TORT05
SCALE 1/2" = 1'		SHEET OF