

4

3

2

1

NOTICE
 THIS DRAWING CONTAINS A PROPRIETARY DESIGN ASSIGNED TO SPIRA INTERNATIONAL, INC. ALL RIGHTS TO DUPLICATE, TRANSFER OR SELL THIS DESIGN ARE EXPRESSLY RESERVED. THE BUYER IS LICENSED TO BUILD ONE ASSEMBLY FROM THESE PLANS.

REVISIONS				
ZONE	LTR	DESCRIPTION	DATE YR/MO/DA	APPROVED

D

D

C

C

B

B

A

A

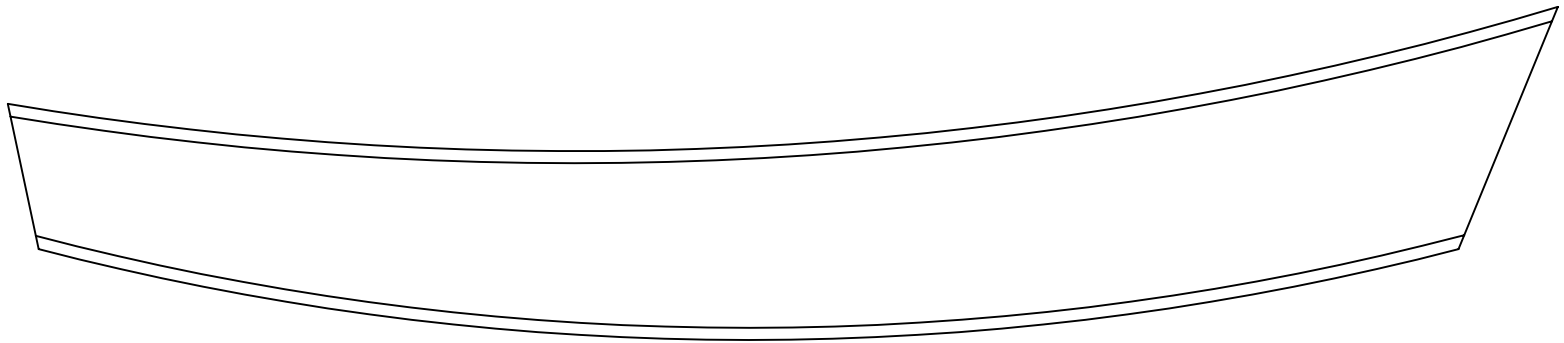
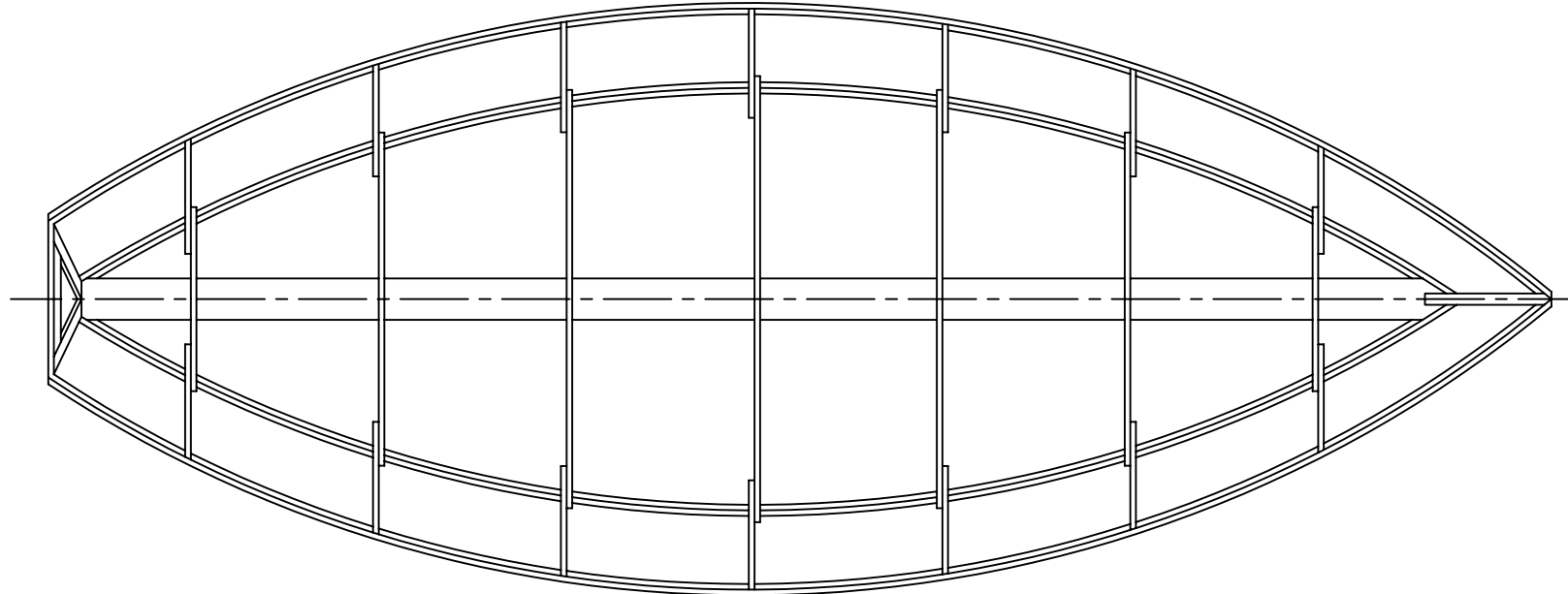

SPECIFICATIONS	
LENGTH	16' 0"
BEAM	6' 6"
HEIGHT	2' 10"
DRAFT	0' 4"
WEIGHT	80 LBS

Spira International, Inc.
 Huntington Beach, California

YUKON
 16' DRIFT BOAT

DRAWN BY: J. SPIRA	DATE: 12/04/00	DRAWING NO. YUK001
-----------------------	-------------------	-----------------------

SCALE 1" = 1' SHEET OF

4

3

2

1

4

3

2

1

NOTICE
 THIS DRAWING CONTAINS A PROPRIETARY DESIGN ASSIGNED TO SPIRA INTERNATIONAL, INC. ALL RIGHTS TO DUPLICATE, TRANSFER OR SELL THIS DESIGN ARE EXPRESSLY RESERVED. THE BUYER IS LICENSED TO BUILD ONE ASSEMBLY FROM THESE PLANS.

REVISIONS				
ZONE	LTR	DESCRIPTION	DATE YR/MO/DA	APPROVED

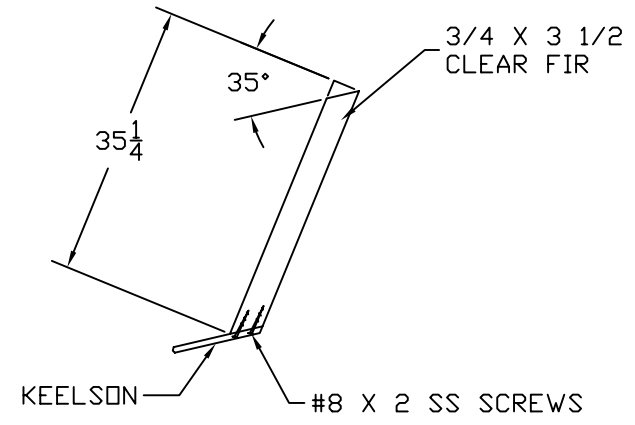
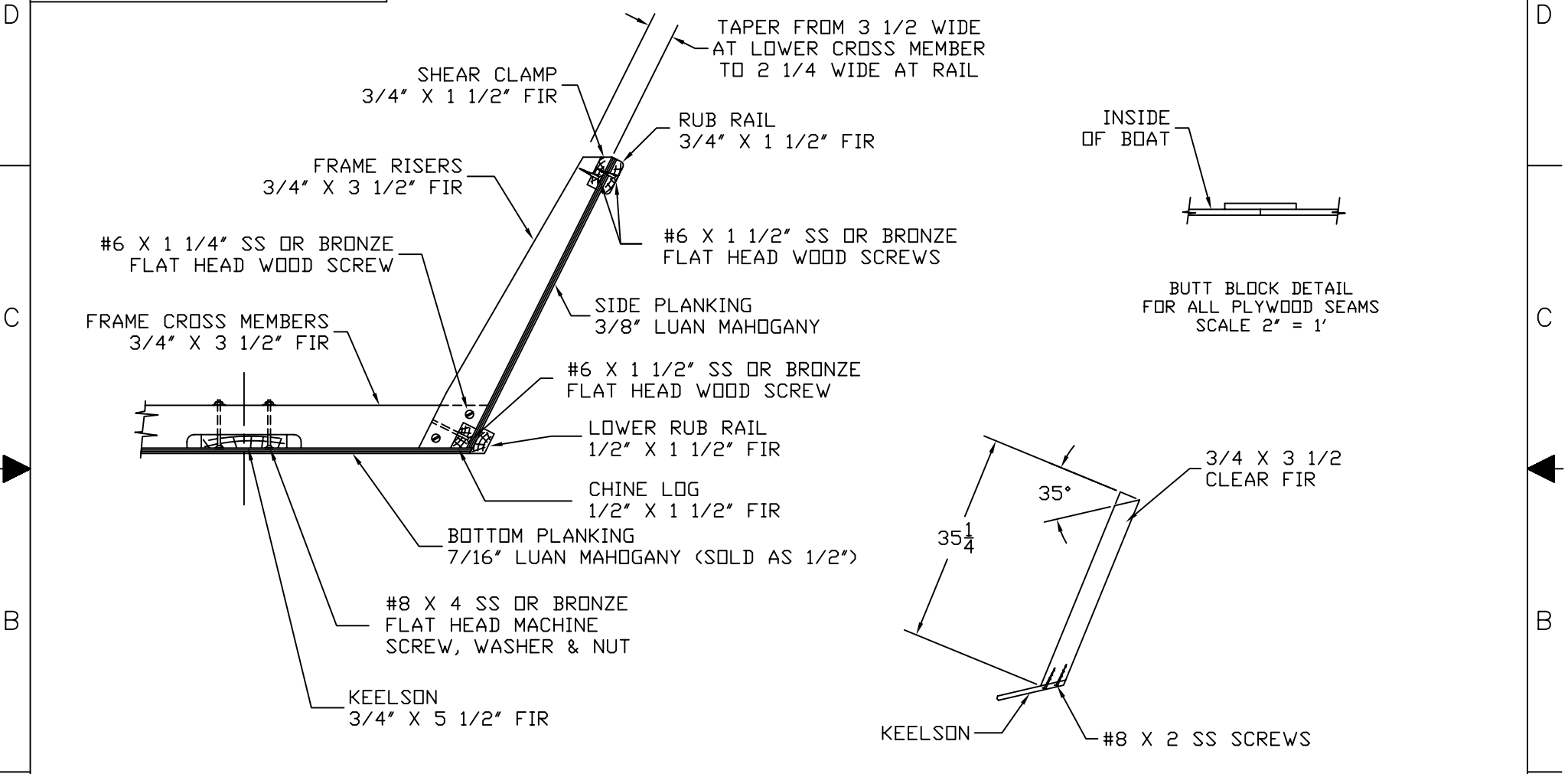

CONSTRUCTION METHOD
 TYPICAL AT ALL FRAMES

STEM DETAILS

4

3

2

1

Spira International, Inc.
 Huntington Beach, California

YUKON
 CONSTRUCTION DETAILS

DRAWN BY: J. SPIRA	DATE: 12/04/00	DRAWING NO. YUK004
SCALE 1" = 1' & NOTED		SHEET OF